

| REV. | ECN NO. | DESCRIPTION | APP. | DATE |
|------|-------------|-------------|-------|------------|
| A | NEW RELEASE | 全自动拉料生产 | YJDAI | 2019.10.26 |

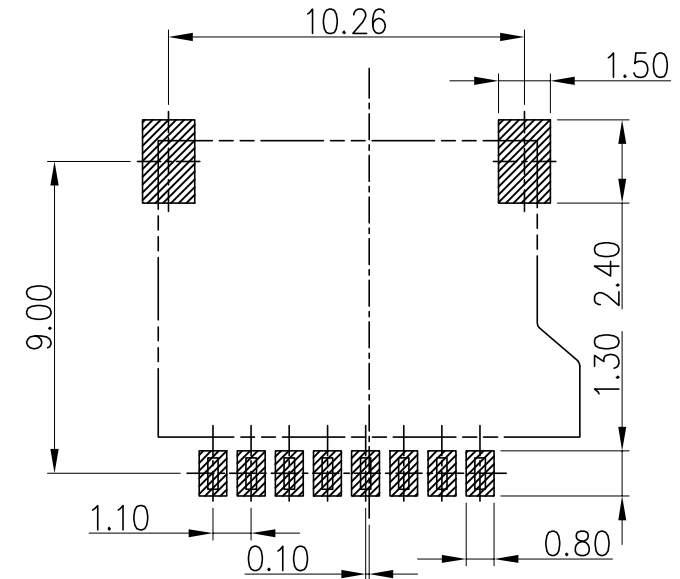
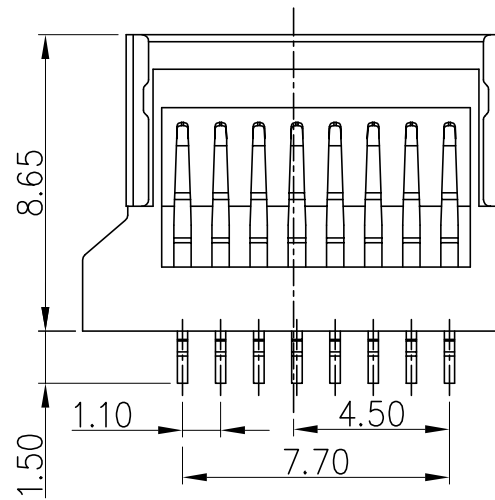
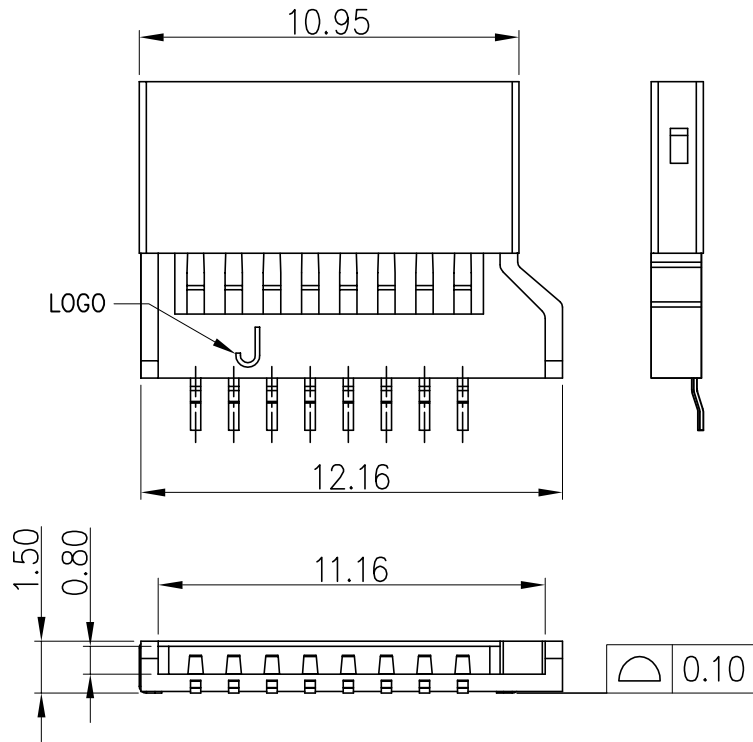
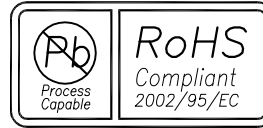

RECOMMENDED PCB LAYOUT
(Witchout Post)

SPECIFICATION

1.MATERIAL

HOUSING: HI-TEMP PLASTIC UL 94V-0; BLACK

CONTACT: COPPER ALLOY

SHELL: STAINLESS STEEL

2.ELECTRICAL CHARACTERISTICS

CONTACT CURRENT RATING: 0.5 AMPERES.

DIELECTRIC WITHSTANDING VOLTAGE: AC500V R.M.S.

INSULATION RESISTANCE: 500 MΩ MIN.

CONTACT RESISTANCE: 40 MΩ MAX.

3.ENVIRONMENTAL

OPERATING TEMPERATURE: -25°C~+90°C

4.ENVIRONMENTAL

MATING CYCLES: 3000 INSERTIONS

5.MECHANICAL CHARACTERISTICS

CARD PUSH INSERTION/OUT FORCE: 0.7~1.20KGF

CONTACT SEPARATION FORCE: 0.20KGF MIN.

THIS PRODUCT SHOULD MEET HAZARDOUS MATERIAL CONTROL DIRECTIVE OF JUN SHENG JIE FROM RAW MATERIAL TO MANUFACTURING, PACKAGE AND DELIVERY.

| 3 | SHELL | 1 | STAINLESS STEEL | Ni: 50u"Min.Overall | t=0.15 |
|------|---------|------|-----------------|--------------------------------|--------|
| 2 | CONTACT | 1 | COPPER ALLOY | Ni: 50u"Min.Overall Au: 1u" | t=0.15 |
| 1 | HOUSING | 1 | THERMOPLASTIC | UL94 V-0, COLOR:BLACK | |
| ITEM | NAME | Q'TY | MATERIAL | FINISH | REMARK |

| | | | | | |
|---|---------------|--|--------------------------------|-----------|--------------|
| TOLERANCES 一般公差 | UNIT : mm | 深圳市君盛捷科技有限公司 Shenzhen Jun Sheng Jie Technology Co.,Ltd | | | |
| DISTANCE X. ±0.25 .X ±0.15 .XX ±0.10 .XXX ±0.05 | | | | | |
| ANGLE X° ±2°.X° ±1°.XX° ±0.5° | DRAWN 制图 | JACK | TITLE : 简易式TF卡1.5H(无柱) | | |
| | CHECKED 审核 | TONY | PARTS NO. : JTFJ03-1508P1-040 | | |
| | APPROVE 核准 | DAVID | DWG NO. : TF-JTFJ03-1508P1-040 | | |
| | | | SIZE A4 | SCALE 1:1 | SHEET 1 of 1 |
| | | | | | REV. A |